

# Aluminum Stair Installation Guide

Product specifications  
Installation Manual

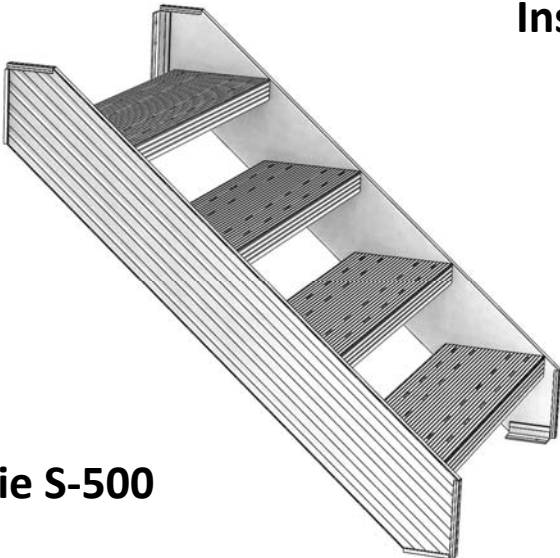

**Serie S-500**

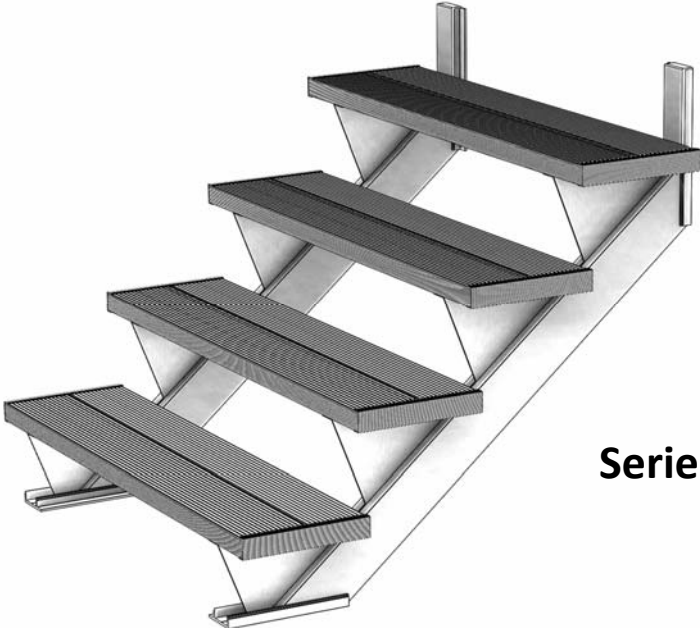

**Serie S-100**



SHAPE THE FUTURE WITH ALUMINUM.

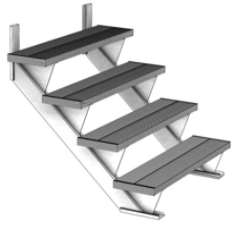

## Serie S-100 Stairs Specification...

The stringer and steps are all made of T-6063 aluminum.

The stringers come fully assembled according to your specifications



The steps are available in 3 different widths

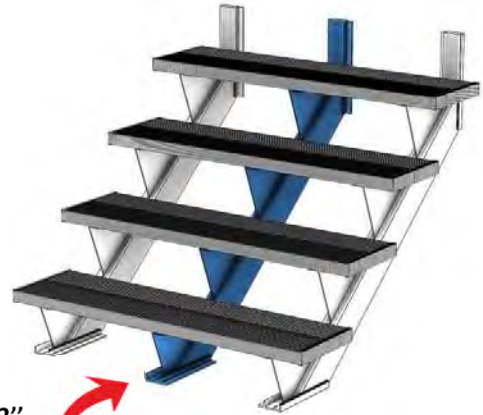
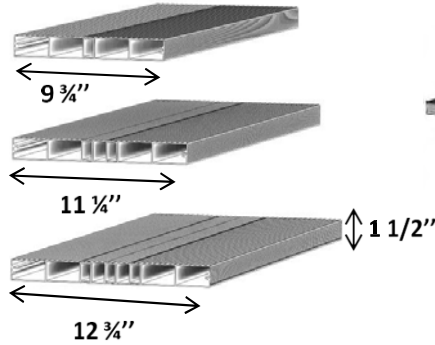

For every 48" inches in width a middle support stringer is added.



Self drilling Screws used to attach Steps to the stringer

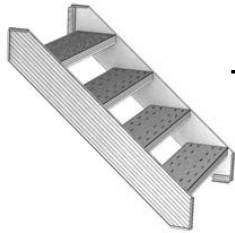

## Serie S-500 Stairs Specification...

The stringer and steps are all made of T-6063 aluminum.

Choice of closed steps S-100 or Open steps S-500

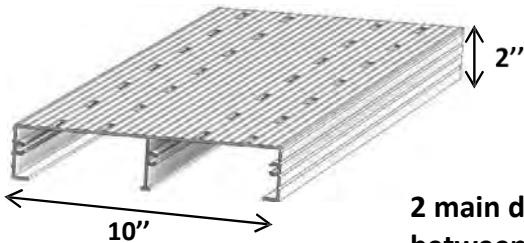
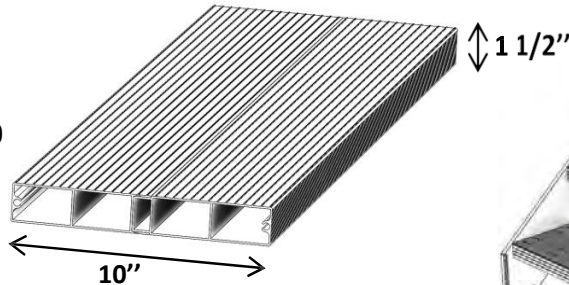

2 main differences between the 2 style steps



For every 48" inches in width a middle support stringer is added.

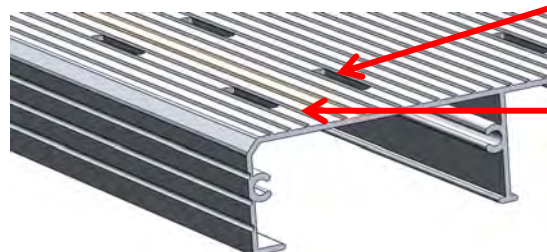

1- Holes in the step allow for faster water evacuation

1- Higher grip grid for better Traction.



## Measuring Stairs for proper dimension...

Calculating stair height without a deck installed...

When measuring the height of your stairs be aware that the slope of the land will influence the height of your stairs.



Use a line level & cord

OR

a laser level

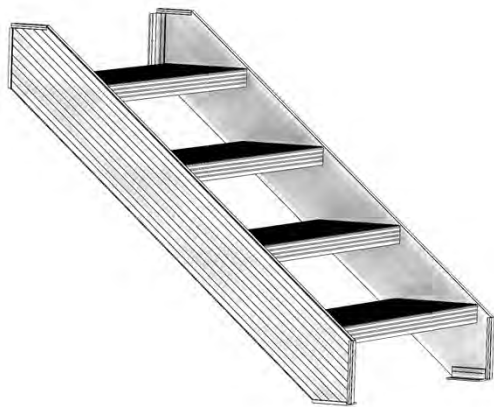
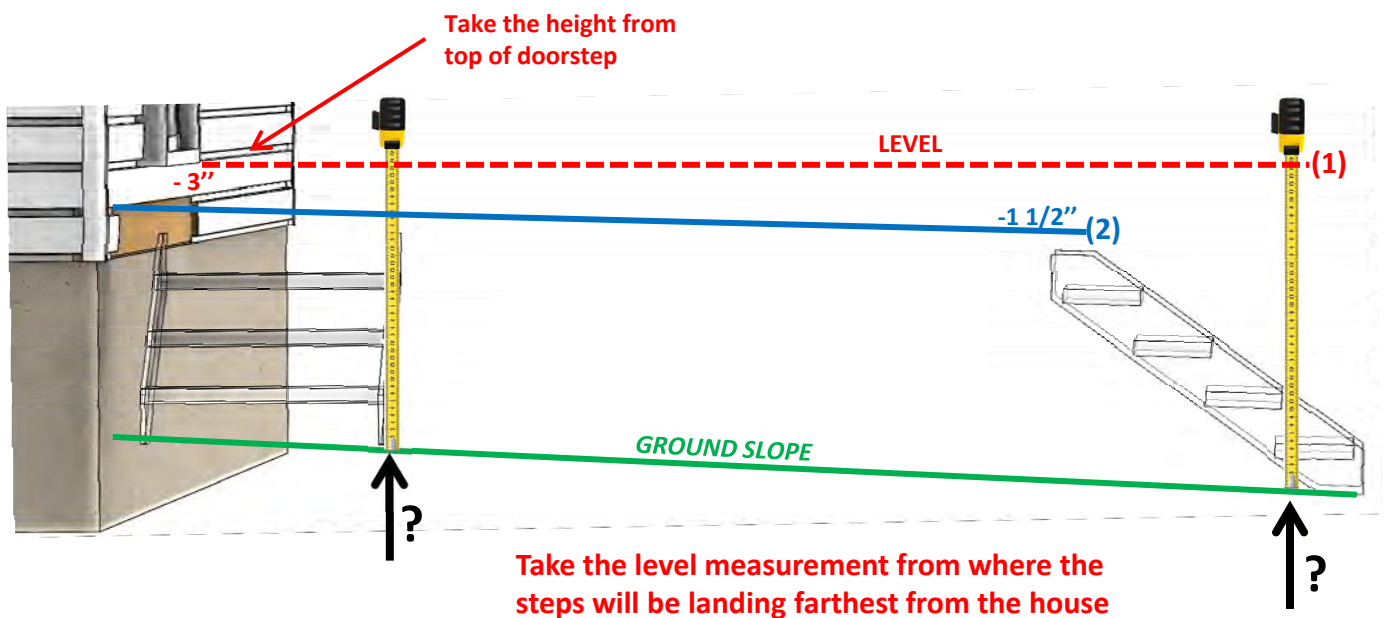
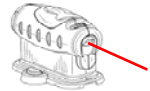

? = Height **GROUND** to **LEVEL LINE**

(1) - 3" Deduct the Space under door

(2) - 1 1/2" Deduct Floor slope

---

= Stair height

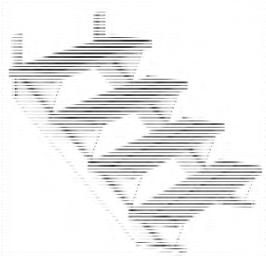

## Measuring stairs for proper dimension...

Calculating stair height with the deck is installed...  
Calculating stair height with the deck is installed...

Take the measure from the top of the floor to the landing.



Use a line level & cord

OR

a laser level

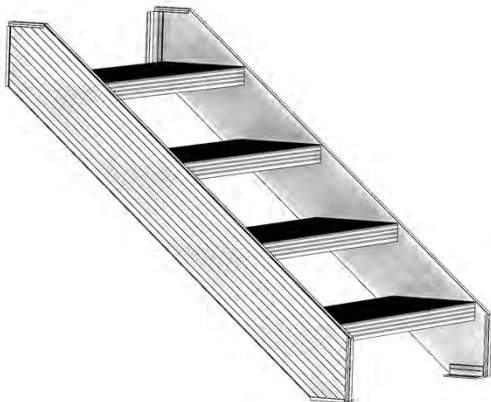
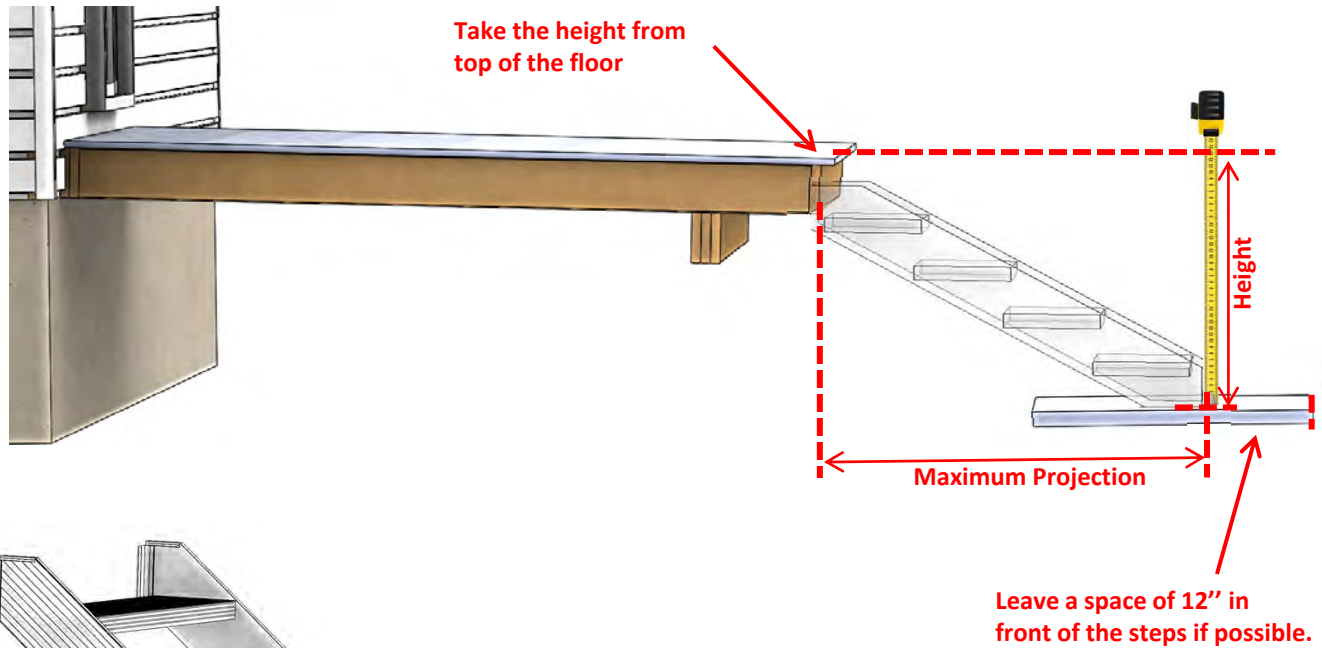
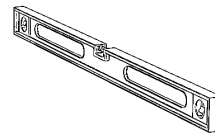
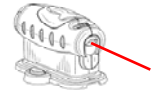

To manufacture stairs that will fit properly, we need to know the height and the maximum projection allowable.

# Serie S-500 Stairs Installation...



Make sure the riser height from the step to the floor from the center of the step is equal to the riser height.

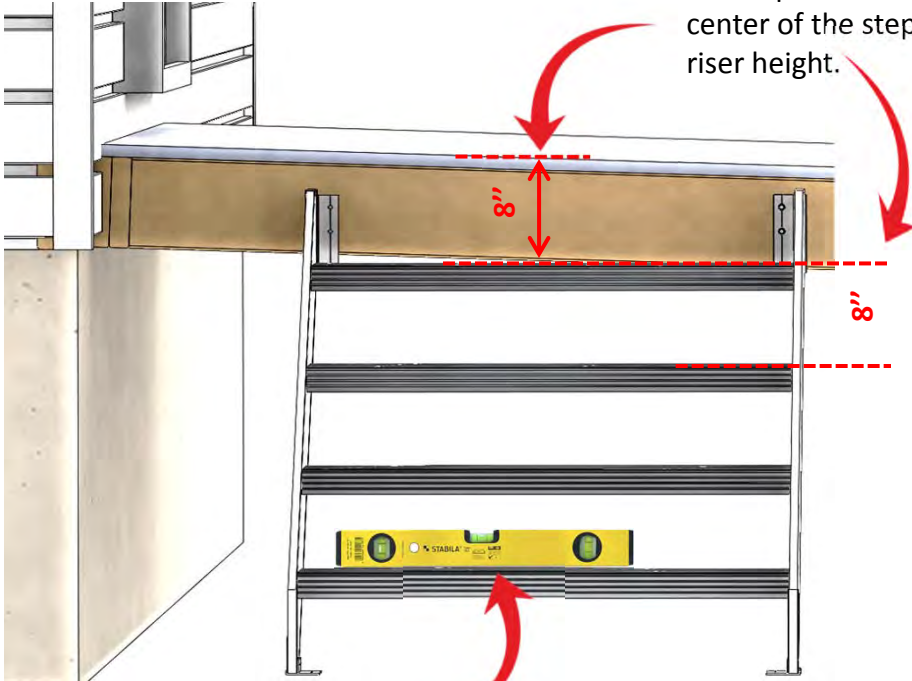

Before screwing the steps in, place the level on the step and make sure all is level

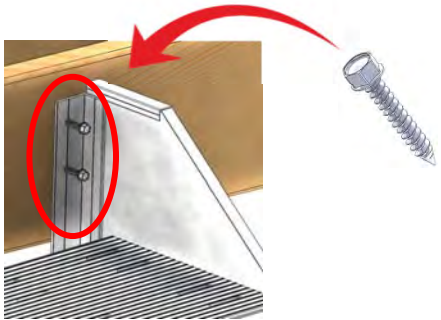

Fix the stair to the structure  
No# 12 -1 1/4" screw

Place the level on the step and adjust the stair level.

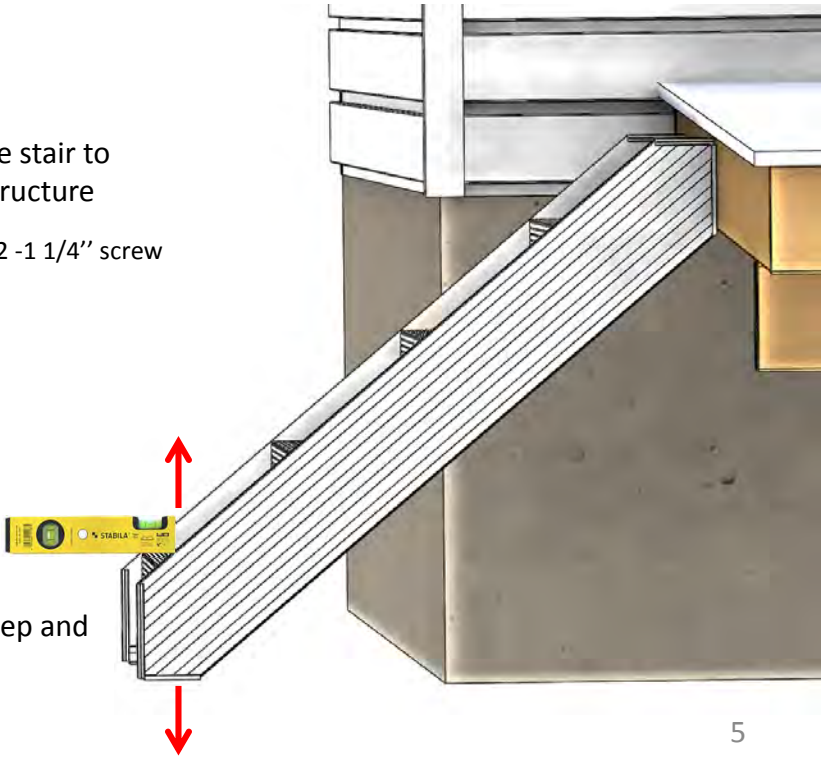



## Aluminum transitional stair landing...

When a landing is required ...

A transitional landing is used when there is a change of direction or when the stairs exceed a height of more than 144".

P-6 Closed Floor on aluminum structure.

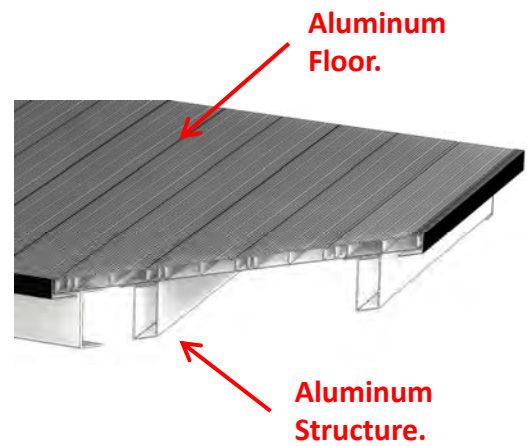

# S-100 STAIR ASSEMBLY

No#	DESCRIPTION
1	TOP PLATE CAP
2	TOP PLATE
3	INSIDE STRINGER STRUCTURE
4	OUTSIDE STRINGER STRUCTURE
5	STEP SUPPORT
6	STEP SUPPORT SCREW
7	STEP HOLDING SCREW
8	STEP SUPPORT NUT
9	BOTTOM PLATE SCREW
10	MALE STEP SECTION
11	FEMALE STEP SECTION
12	STEP FINISHING CAP
13	BOTTOM PLATE

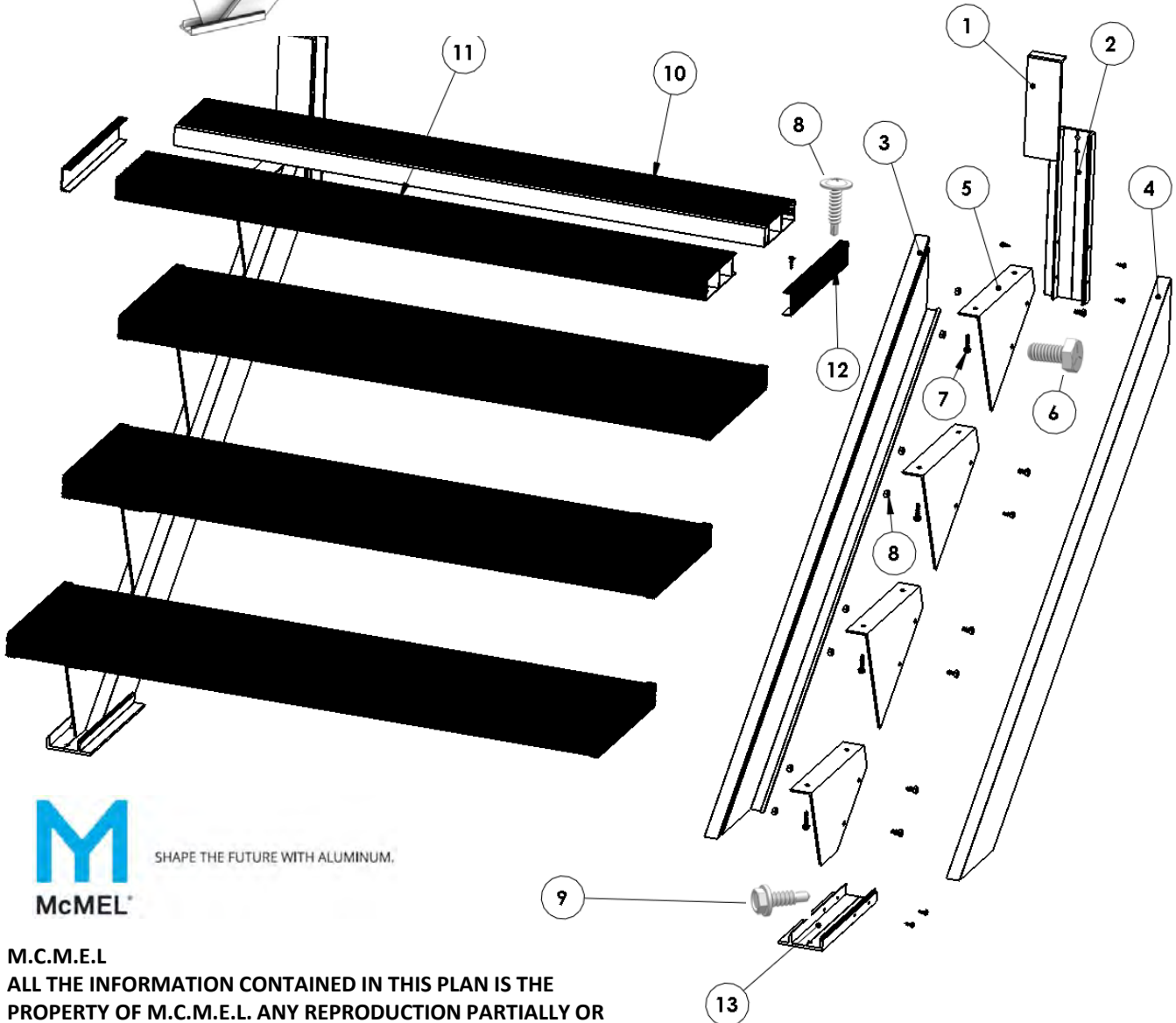

SHAPE THE FUTURE WITH ALUMINUM.

**M.C.M.E.L**  
 ALL THE INFORMATION CONTAINED IN THIS PLAN IS THE  
 PROPERTY OF M.C.M.E.L. ANY REPRODUCTION PARTIALLY OR  
 IN FULL WITHOUT WRITTEN AUTHORIZATION BY M.C.M.E.L IS  
 STRICTLY FORBIDDEN.

## S-500 STAIR ASSEMBLY

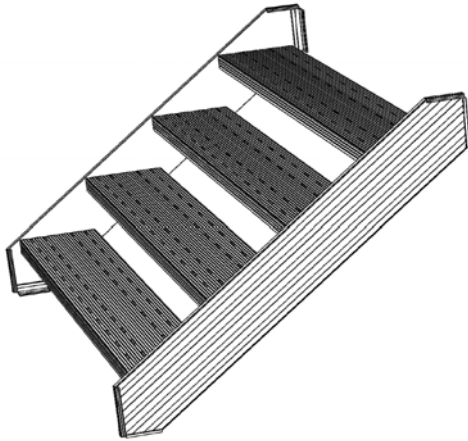

No#	DESCRIPTION
1	TOP FINSHING CAP
2	TOP PLATE
3	INSIDE STRINGER STRUCTURE
4	OUTSIDE STRINGER STRUCTURE
5	S-500 OPEN STEP
6	SELF DRILLING SCREW
7	STEP SCREW
8	BOTTOM PLATE
9	BOTTOM FINSHING CAP

